

## MULTIFUNCTION DOOR BAR

- The Multifunction door bar is easy to assemble, user only need to secure the pieces together tightly with nuts & screws provided.
- The Multifunction door bar will fit door frame between 24 and 32 inches wide.
- Max. Weight capacity: 250 lbs.

### IMPORTANT:

- Before installing the door bar, make sure door frame and molding are secure and solid, a weak door frame and/or moldings can cause the door bar to fail and dislodge from the door way.
- Before using the door bar, make sure the door bar is securely installed into the door frame.
- Warm-up exercise is necessary before you start to do any workouts. If you feel strain or pain when you are exercising, stop immediately and consult your physician.
- The door bar is not a toy; keep away from children, adult supervision recommended for users under 16 years old.

### Parts:

# 1 Arched Bar Grips

# 2 Cross Bar

# 3 Long Bar (Right Half)

# 4 Long Bar (Left Half)

# 5 Nuts

# 6 Bolts

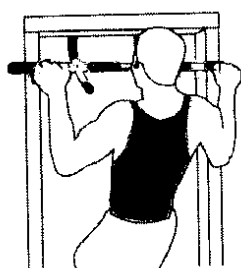
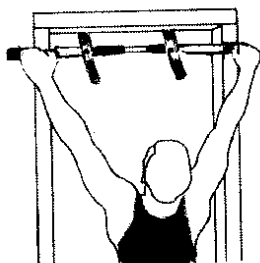
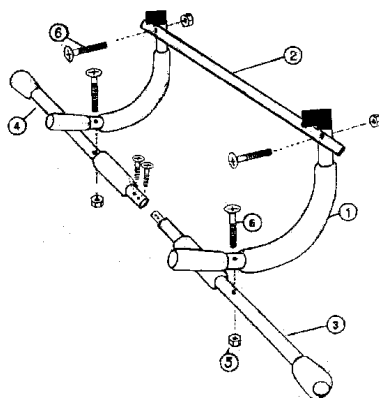

Place the door bar in the door frame; hold the grips, bending your knees, pull up slowly as much as possible. Slowly return to starting position and repeat the workout.

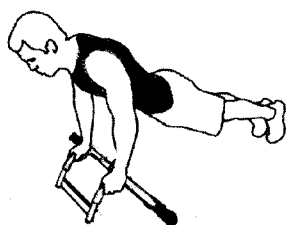

Place the door bar on the floor; grab the bar with both hands, slowly lower yourself towards the floor until you reach the bottom of the push. Slowly return to starting position and repeat the

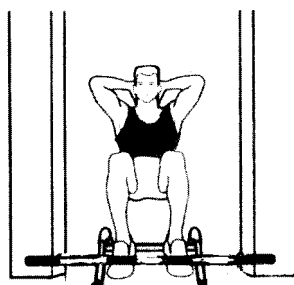
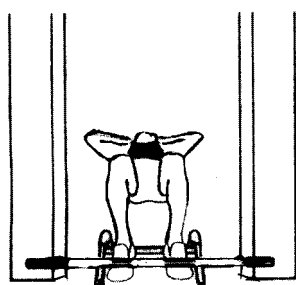

Lie face up on the floor, bend both knees and place your feet under the long bar, bend your elbows and place both hands on either side of your head and using your abs, slowly lift your upper torso. Slowly return to starting position and repeat the workout.